

### Beyond the first few hours - Reliable Power from Hydrogen Adoption

The opportunity for Fuel Cell deployment is well understood in the Telecommunications sector, with such benefits as lower weight and space occupancy, lower maintenance needs, reduced fuel logistics together with the environmental cleanness of Fuel Cells, easily demonstrate advantages over legacy technologies such as batteries and diesel generators.

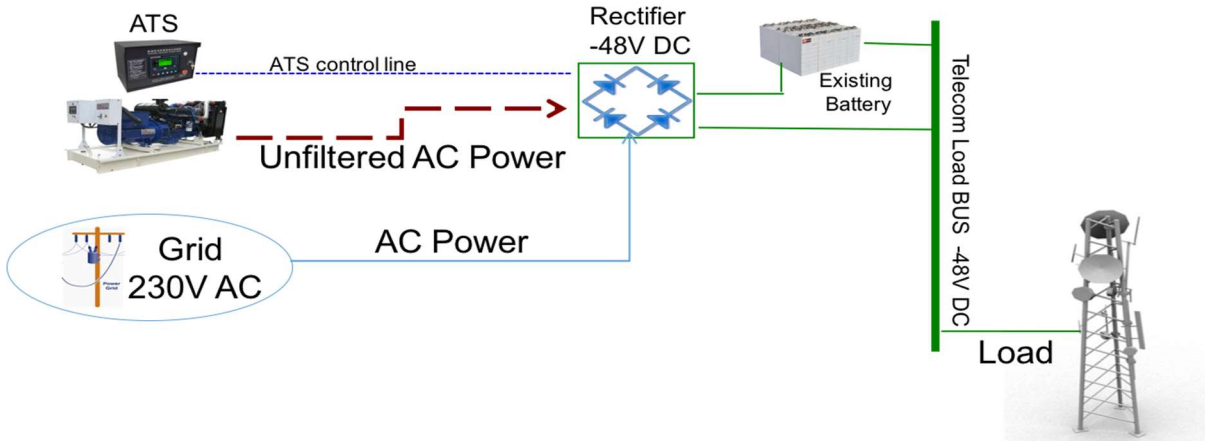

### Reducing Existing OpEx – Diesel Generators (Diesel generator)

A significant portion of existing operating expense (OpEx) of a Telecom Base Station is the maintenance requirement of Diesel generators. Frequent oil changes, air, oil, and fuel filter maintenance, cooling system, belt maintenance, and maintaining the condition of the starting battery add significantly to site operational expense. Scheduled maintenance of a Fuel Cell system by comparison only consists of one air filter, which is washable and typically need to be changed once a year.

Diesel generators for telecom applications are usually over dimensioned because larger generators have higher reliability, are more difficult to steal, and can accommodate higher inrush currents. Peak efficiency of these Diesel generators often exceeds 20%, but efficiency quickly drops to less than 10% at power levels below rated output. Therefore, in most telecom applications, the Diesel generator will spend a large portion of time operating at low efficiency.

In contrast, a Fuel Cell system “load follows” and operates at over 50% efficiency. Because the output is more closely matched to the load, the system spends much of the time operating at a higher efficiency.

| Maintenance Items           | Day | Week | Month | Half year | Yearly |
|-----------------------------|-----|------|-------|-----------|--------|
| Inspection                  | X   |      |       |           |        |
| Check coolant heater        | X   |      |       |           |        |
| Check Coolant level         | X   |      |       |           |        |
| Check oil level             | X   |      |       |           |        |
| Check fuel level            | X   |      |       |           |        |
| Check charge-air piping     | X   |      |       |           |        |
| Check/clean air cleaner     |     | X    |       |           |        |
| Check battery charger       |     | X    |       |           |        |
| Drain fuel Filter           |     | X    |       |           |        |
| Drain water from fuel tank  |     | X    |       |           |        |
| Check coolant concentration |     |      | X     |           |        |
| Check drive belt tension    |     |      | X     |           |        |
| Drain exhaust condensate    |     |      | X     |           |        |
| Check starting batteries    |     |      | X     |           |        |
| Change oil and filter       |     |      |       | X         |        |
| Change coolant filter       |     |      |       | X         |        |
| Clean crankshaft breather   |     |      |       | X         |        |
| Change air cleaner element  |     |      |       | X         |        |
| Check radiator hoses        |     |      |       | X         |        |
| Change fuel filters         |     |      |       | X         |        |
| Clean cooling system        |     |      |       |           | X      |

The simplicity and low number of moving parts in a Fuel Cell system contributes to high reliability and low levels of vibration transmitted to surrounding structures.

Additionally, a running Fuel Cell generates very little noise, which enables the system to be located close to offices or residential neighborhoods. This is a major advantage for telecom uses particularly in areas that face “community issues” relating to noise from existing diesel generators.

### Reducing Existing OPEX – Batteries

Power output of a Fuel Cell system is Direct Current (DC) and therefore directly compatible with a telecom base stations equipment, avoiding losses from AC to DC inverters. An additional benefit of replacing an AC generator (i.e., a Diesel Generator) with a Fuel Cell system is the possibility to decrease both the number of rectifiers and the size of the battery bank because the characteristic power surge from the AC generator is eliminated when the DC Fuel Cell system generator is used.

The traditional telecom approach to backup power is to implement large battery strings – typically 400 or more amp-hours capacity – of VRLA (valve regulated lead acid) batteries for backup. These large battery strings require air conditioning systems for cooling, and the associated air conditioners consume high amounts of power – typically 40% or more of the entire BTS load is for air conditioning. VRLA batteries have a short lifetime (< 3 years) if not maintained at 25°C and are often also the target of theft in addition to diesel fuel.

In contrast a Fuel Cell system starts quickly and operates efficiently, while following the load, thereby foregoing the need for a large battery bank. In most cases, a relatively small bridging battery of 100 to 150 amp-hours is required to carry the load while the Fuel Cell system is starting, resulting in a 60% or higher reduction in battery capacity.

### Total Cost of Ownership (TCO)

I use a TCO (total cost of ownership) approach in evaluating the suitability of a Fuel Cell system for each application.

In many cases the TCO analysis shows that the payback of the cost of a Fuel Cell, over a Diesel generator is less than two years and if the benefits of the improved site reliability are included, the payback period is significantly accelerated.

- ✓ Savings: thanks to its high efficiency the operation costs of a Fuel Cell are very low and the overall TCO is considerably lower than legacy technologies (diesel gen. + batteries).
- ✓ No fuel theft: Hydrogen based fuel cannot be used for traditional uses such as powering/ heating houses or running cars.
- ✓ OPEX independent from fuel price volatility: the main energy source is hydrogen, widely used in Industry and whose cost is historically far less volatile than the cost of diesel/oil/gas.
- ✓ Easy and low-cost maintenance: the system is fully remotely managed, there is NO NEED for on-site checks. A Self-test procedure verifies the status of all the components, while a fuel meter monitors hydrogen fuel storage.
- ✓ No Noise and small foot print means more opportunities to deploy system in VIP sites or restricted space locations.

In addition to the OPEX cost savings of low maintenance and high efficiency, the use of a Fuel Cell as backup power solution, will provide additional indirect saving such as:

- ✓ Improve site availability: increase revenues generated by site. <sup>[1]</sup><sub>[SEP]</sub>
- ✓ Space saving: the footprint of a Fuel Cell is less than a Diesel generator and fuel tank.
- ✓ Rectifier redundancy saving: since the Fuel Cell system is a standalone DC power system it will not only back-up the grid supply but also act as a rectifier in case of failure.
- ✓ Reduced number of rectifiers: since the current surge from the diesel generator is eliminated. <sup>[1]</sup><sub>[SEP]</sub>
- ✓ ATS cost saving: Fuel Cell system does not require the use of costly and unreliable automatic transfer switches. <sup>[1]</sup><sub>[SEP]</sub>
- ✓ Battery recharging cost: Power consumption cost to recharge batteries and maintain the floating voltage is eliminated. <sup>[1]</sup><sub>[SEP]</sub>

*Benefits Score of a Methanol Reformer Fuel Cell (MFC)*

|                               | MFC       | Battery  | Genset   |
|-------------------------------|-----------|----------|----------|
| Low Energy Cost               | ✓         | ✓        | ✗        |
| Low System Cost per kW/h      | ✓         | ✗        | ✓        |
| Low System Cost per kWp       | ✗         | ✓        | ✗        |
| Flat Power Output             | ✓         | ✗        | ✓        |
| No Fuel Logistics             | ✓         | ✓        | ✗        |
| Long System Life on Stand-by  | ✓         | ✗        | ✓        |
| Long System Life in Service   | ✓         | ✓        | ✗        |
| Fast Start-Up                 | ✓         | ✓        | ✗        |
| Low Maintenance Cost          | ✓         | ✓        | ✗        |
| Fuel Price Stability          | ✓         | ✓        | ✗        |
| Low Theft Risk                | ✓         | ✗        | ✗        |
| Wide Temperature Limits       | ✓         | ✗        | ✓        |
| Non-Polluting                 | ✓         | ✓        | ✗        |
| Low Noise                     | ✓         | ✓        | ✗        |
| Easy Disposal                 | ✓         | ✗        | ✓        |
| <b>Total Benefits (Score)</b> | <b>14</b> | <b>9</b> | <b>5</b> |